

THIS COPY IS PROVIDED ON A RESTRICTED BASIS AND IS NOT TO BE USED IN ANY WAY DETRIMENTAL TO THE INTERESTS OF PANDUIT CORP.

PANDUIT PART #	STUD SIZE		DIMENSIONS in. [mm]					CA9 SERIES CRIMP DIE	CA-800(EZ) SERIES CRIMP DIE
	ENGLISH	METRIC	L ± .03 [0,76]	W ± .01 [0,25]	C ± .02 [0,51]	M ± .03 [0,76]	H ± .01 [0,25]		
PV10-6FB-2K	#6	M3, 5	.99 [25,2]	.30 [7,6]	.22 [5,6]	.78 [19,8]	.15 [3,8]	CD9-3B	CD-800-3
PV10-8FB-2K	#8	M4	1.00 [25,4]	.30 [7,6]	.22 [5,6]	.78 [19,8]	.17 [4,3]		
PV10-10FB-2K	#10	--	1.04 [26,4]	.34 [8,6]	.22 [5,6]	.78 [19,8]	.20 [5,0]		
PMV6-5FB-2K	--	M5	1.02 [25,9]	.38 [9,7]	.24 [6,2]	.79 [20,1]	.21 [5,3]		
PV10-14FB-2K	1/4"	M6	1.13 [28,7]	.49 [12,5]	.32 [8,1]	.88 [22,4]	.27 [6,9]		

PRESS/APPLICATOR COMPATIBILITY CHART

PRESS	CP-871	CP-861
APPLICATOR	CA9 CA-800EZ	CA-800

NOTES:

- cULus LISTED FOR:
  - A. #12-10 AWG [4,0-6,0 mm<sup>2</sup>] SOLID OR STRANDED COPPER WIRE
  - B. 221°F [105°C] MAX. OPERATING TEMPERATURE
  - C. 600 V. MAX. VOLTAGE RATING
- SEE [www.panduit.com](http://www.panduit.com) FOR PACKAGE QUANTITIES
- MATERIAL:
  - A. STAMPING: .04" [1,0] THK COPPER, TIN PLATED
  - B. HOUSING: VINYL, YELLOW
- DIMENSIONS IN BRACKETS ARE METRIC EQUIVALENT
- WIRE STRIP LENGTH: 11/32 <sup>+1/32</sup>/<sub>0</sub> [8,7 <sup>+0,8</sup>/<sub>0</sub>]

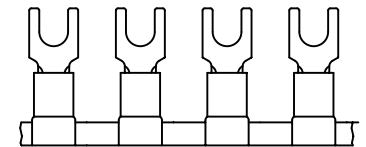
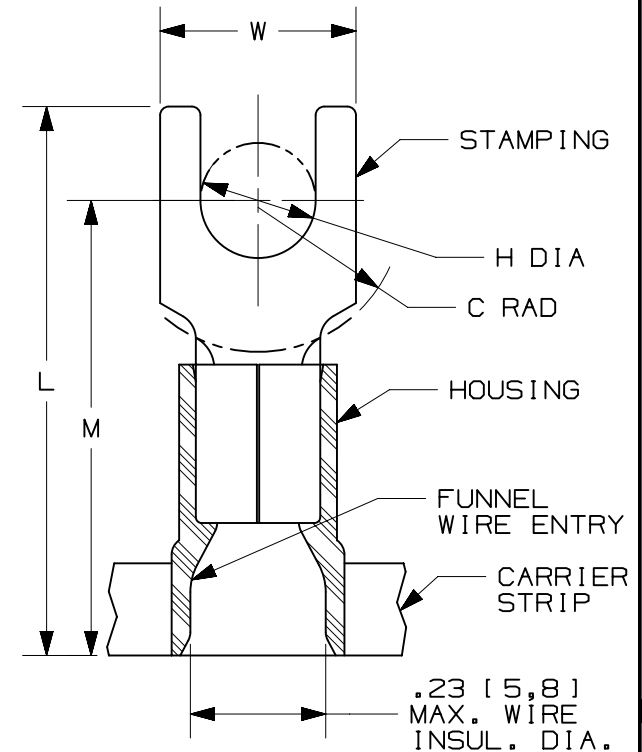

REV	DATE	BY	CHK	APR	DESCRIPTION	ECN
07	07/14	MBY	JHNU	RGB	REVISED NOTES, MOVED TOOLS TO TABLE, REVISED CERTIFICATION	N41079-A41079
06	09.07.12	JBN	LCA	VMB	ADDED METRIC EQUIVALENT. REVISED NOTES. UPDATED DRAWING TO CURRENT STANDARDS.	A41079

TITLE <b>FORK TERMINALS, 2 PC. VINYL INSULATED, #12-10, CONTINUOUS REEL</b> CUSTOMER DRAWING			
ITEM REVISION NAME N41079BA/07		<b>PANDUIT</b>	
DATASET FILE NAME N41079BA_DC/07A			
UNLESS OTHERWISE SPECIFIED, DIMENSIONAL TOLERANCES ARE: IN [mm]		MATERIAL: SEE NOTES	
DRAWING NUMBER: <b>A41079</b>		DRAWING NUMBER: <b>A41079</b>	
DRAWN BY LM	DATE -	CHK -	SCALE N.T.S.
SHT 1 OF 1		A	

D10100DA/15